

GENERAL DESCRIPTION

The SP7500 incorporate on a single monolithic chip all the functions required in the construction of a pulse-width- modulation control circuit. Designed primarily for power supply control ,these devices offer the systems engineer the flexibility to tailor the power supply control circuitry to hos application. The SP7500 contains an error amplifier , anon-chip adjustable oscillator ,a dead- time control comparator ,pulse-steering control flip-flop ,a 5-volt, 1% precision regulator , and output-control circuits. The error amplifier exhibits a common-mode voltage range from -0.3 volts to $V_{cc} - 2$ volts .The dead time control comparator has a fixed offset that provides

approximately 5% deed time when

bypassed by terminating RT (pin 6) to the reference output and providing a sawtooth input to Ct (pin 5) ,or it may be used to drive the common circuits in synchronous multiple-rail power supplies . The uncommitted output transistors provide either common circuits in synchronous Power supplier. The uncommitted output transistors provide either common-emitter or emitter-follower output capability .Each device provides for push-pull or single-ended output operation, which may be selected through the

output - control function . The architecture of these devices prohibits the possibility of either output being pulsed twice during push-pull operation.

FEATURES

- ◆ Complete PWM Power Control Circuitry.
- ◆ Uncommitted Outputs for 200 Ma sink or Source Current
- ◆ Output control Selects Singel-Ended or Push-Pull operation
- ◆ Internal Circuitry Prohibits Double Pulse at Either output
- ◆ Variable Dead-Time Provides Control over Total Range Internal
- ◆ Regulator Provides a Stable 5-V Reference supply ,1%
- ◆ Circuit Architecture Allows Easy Synchronization
- ◆ Package outline: DIP16

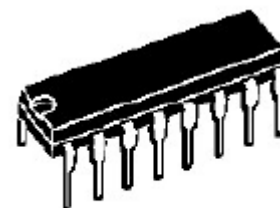

DIP - 16

Block Diagram

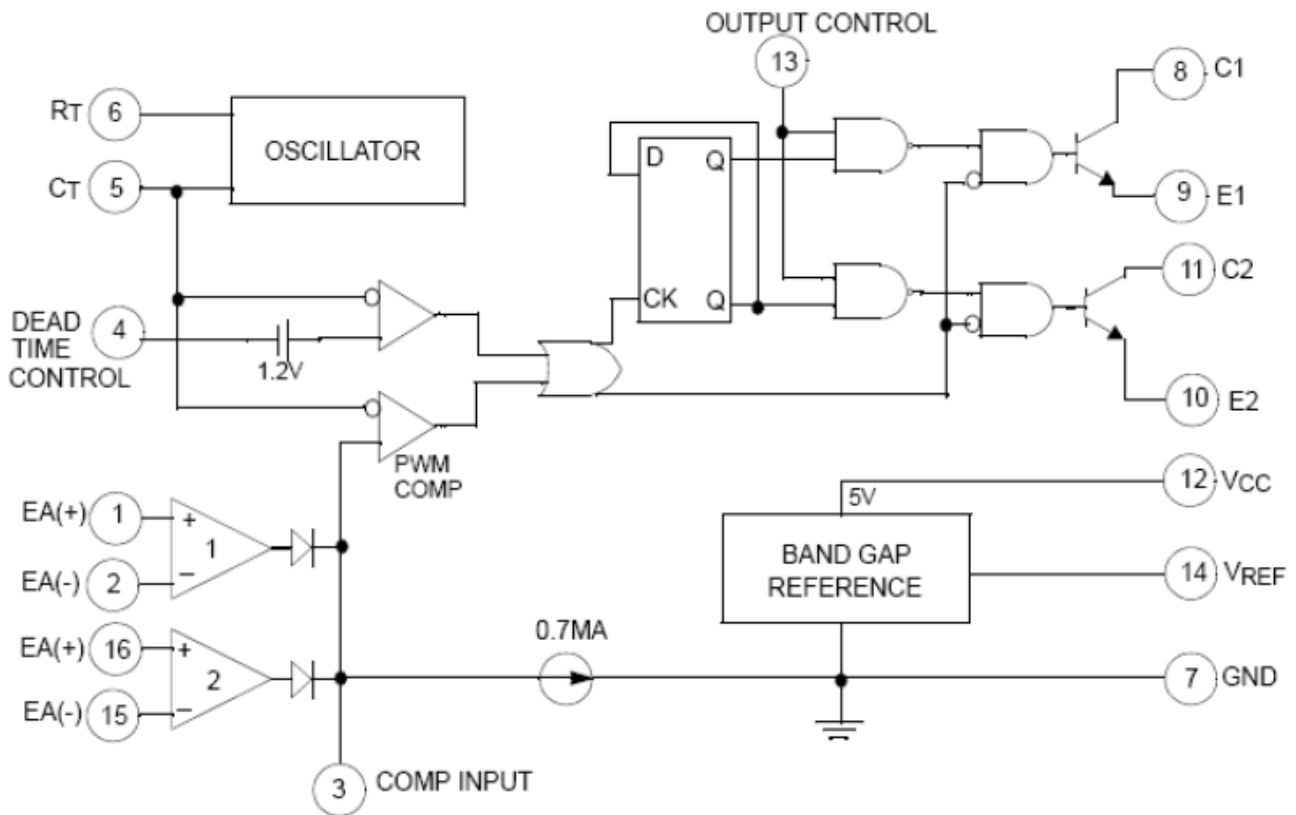

Absolute Maximum Ratings

Over Operating Free-air Temperature Range (Unless Otherwise)

Rating	Value	Unit
Supply voltage ,Vcc	42	V
Amplifier input voltage	Vcc+0.3	
Collector output voltage	41	
Collector output current	250	mA
Operating free-air temperature range	0 to 70	° C
Storage temperature range	-65 to 150	
Lead temperature 1,6 mm from case for 10 seconds	260	

Recommended Operating Conditions

Parameter	Value		Unit
	MIN	MAX	
Supply voltage ,Vcc	7	40	V
Amplifier input voltage,Vi	-0.3	Vcc-2	
Collector output voltage,Vo		40	
Collector output current(each transistor)		200	mA
Current into feedback terminal		0.3	
Timing capacitor ,CT	0.0047	10	μF
Timing resistor ,RT	1.8	500	kΩ
Oscillator frequency	1	200	kHz
Operating free-air temperature ,TA	0	70	° C

Electrical Characteristics

Over Operating Free-air Temperature Range,Vcc=15V,f=10kHz (Unless Otherwise Noted)

Parameter	Test conditions	Value			Unit
		MIN	TYP**	MAX	
Output voltage(Vref)	Io=1mA	4.9	5	5.1	V
	Io=1mA,TA=25° C****	4.95	5	5.05	
Line regulation	Vcc=7V to 40V		2	25	mV
Load regulation	Io=1Ma to 10mA		1	15	
Short-circuit output current ^{t***}	Vref=0	10	35	50	mA

Oscillator section (See Figure 1)

Parameter	Test conditions*	Value			Unit
		MIN	TYP**	MAX	
Frequency	CT=0.01μF,RT=12KΩ,TA=25° C	9.2	10	10.8	kHz
Frequency	CT=0.01μF,RT=12KΩ	9.0	-	12	
Frequency change with temperature *****	CT=0.01μF,RT=12KΩ Δ TA=MIN TO MAX			2	

Amplifier section (See Figure 2)

Parameter	Test conditions*	Value			Unit
		MIN	TYP**	MAX	
Input offset voltage	$V_o(\text{pin } 3)=2.5\text{V}$		2	10	mV
Input offset current	$V_o(\text{pin } 3)=2.5\text{V}$		25	250	nA
Input bias current	$V_o(\text{pin } 3)=2.5\text{V}$		0.2	1	μA
Common-mode input voltage range	$V_{cc}=7\text{V to } 40\text{V}$	-0.3 to $V_{cc}-2$			V
Open-loop voltage amplification	$\Delta V_o=3\text{V}, R_L=2\text{K}\Omega,$	70	95		dB
Unity-gain bandwidth			650		kHz

Output Section

Parameter		Test conditions*	Value			Unit
			MIN	TYP**	MAX	
Collector off-state current		$V_{CE}=40\text{V}, I_{Ccc}=40\text{V}$		2	100	μA
Emitter off-state current		$V_{cc}=V_c=40\text{V}, V_E=0$			-100	
Collector-emitter saturation voltage	Collector-emitter	$V_E=0, I_c=200\text{mA}$		1.1	1.3	V
	Emitter-follower	$V_C=15\text{V}, I_E=-200\text{mA}$		1.5	2.5	
Output control input current		$V_I=V_{ref}$			3.5	mA

Dead -Time Control - Section(See Figure1)

Parameter	Test conditions*	Value			Unit
		MIN	TYP**	MAX	
Input bias current (pin 4)	$V_I=0 \text{ to } 5.25\text{V}$		-2	-10	μA
Maximum duty cycle, each output	$V_I(\text{pin } 4)=0, O.C.=V_{ref}$	45			%
Input threshold voltage (pin 4)	Zero duty cycle		3	3.3	
	Maximum duty cycle	0			V

P M Comparator Section(See Figure 1)

Parameter	Test conditions*	Value			Unit
		MIN	TYP**	MAX	
Input threshold voltage(pin 3)	Zero duty cycle		4	4.5	V
Input sink current (pin 3)	$V(\text{pin } 3)=0.7\text{V}$	0.3	0.7		mA

Total Device

Parameter	Test conditions*	Value			Unit
		MIN	TYP**	MAX	
Standby supply current	Pin 6 at Vref Vcc=15V		6	10	mA

Switching Characteristics, TA= 25° C

Parameter	Test conditions	Value			Unit
		MIN	TYP**	MAX	
Output voltage rise time	Common-emitter configuration, See figure 3		100	200	ns
Output voltage fall time			25	100	
Output voltage rise time	Emitter-follower configuration. See Figure 4		100	200	
Output voltage fall time			25	100	

*For conditions shown as MIN or MAX, use the appropriate value specified under recommended operating conditions.

**All typical values except for parameter changes with temperature are at TA=25° C

***Duration of the short-circuit should not exceed one second

****This is guaranteed where the marking code on the package surface is "A"

*****Temperature coefficient of timing capacitor and timing resistor not taken into account.

Parameter Measurement Information

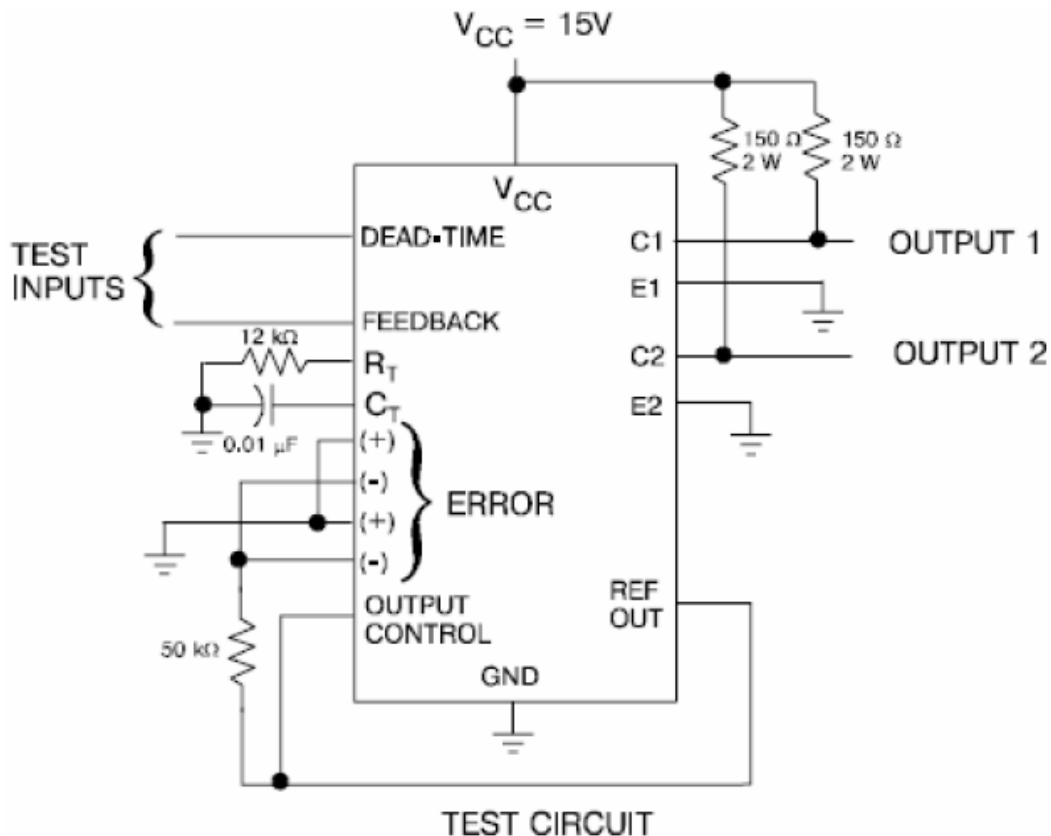

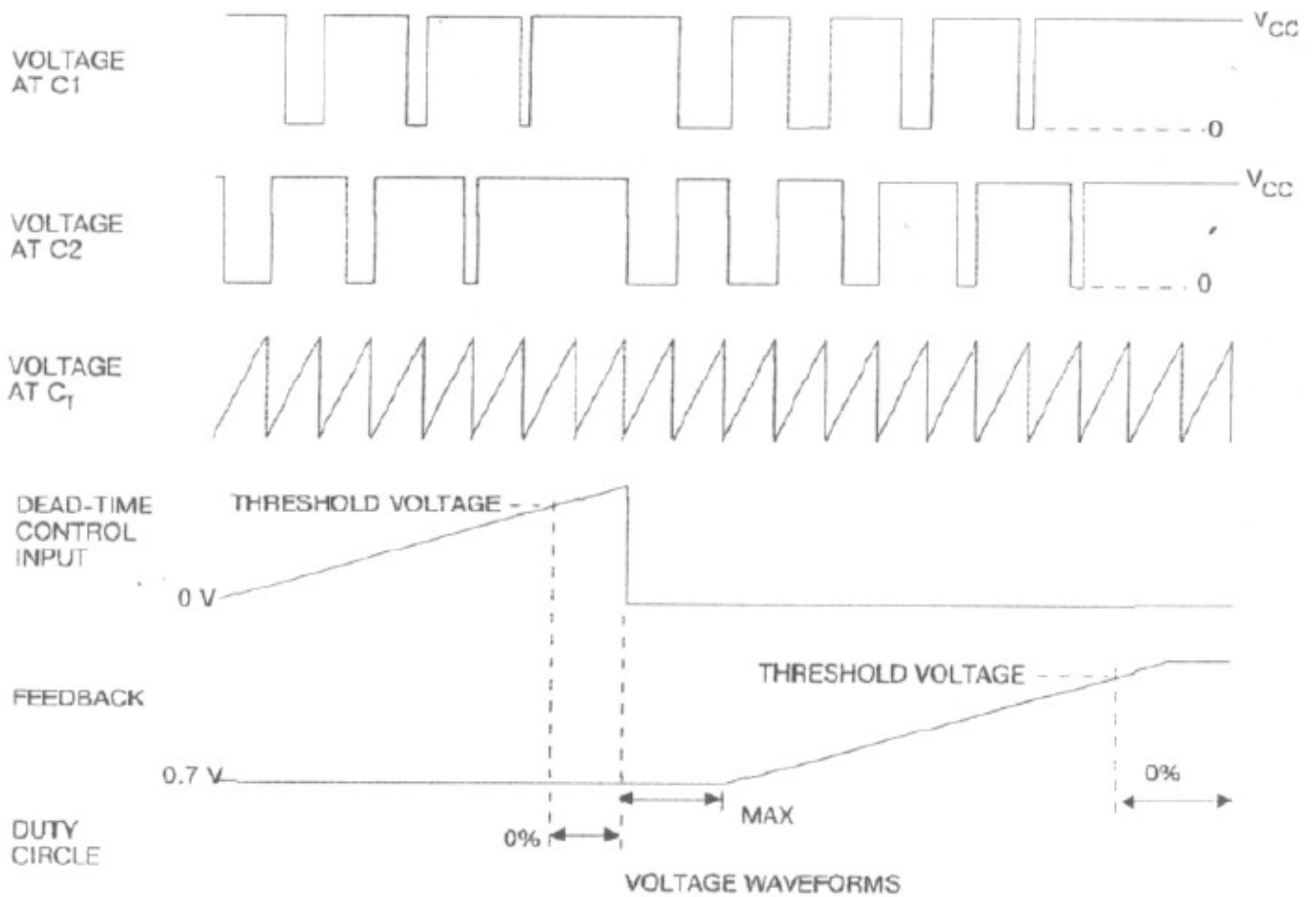

Figure 1. Operational test circuit and waveforms

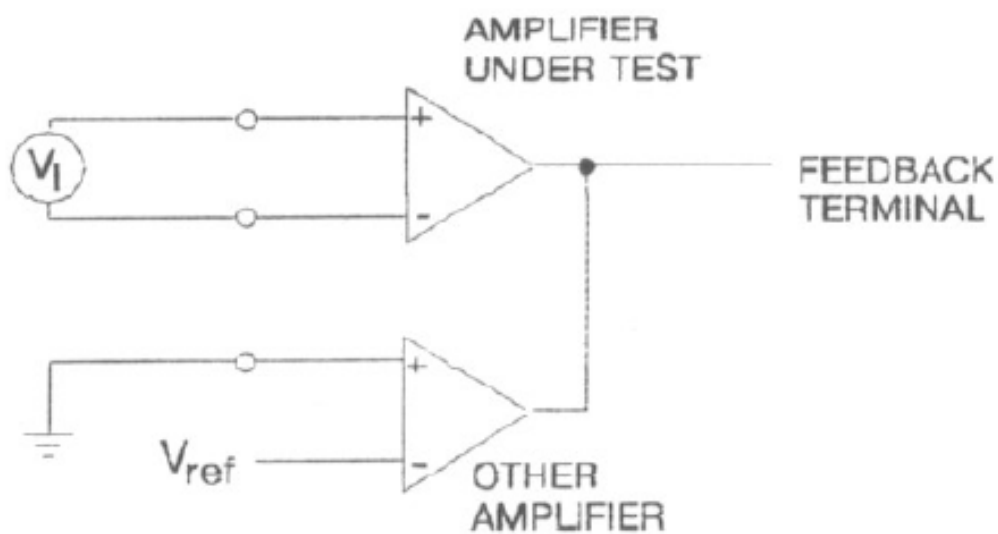

Figure 2. Amplifier characteristics

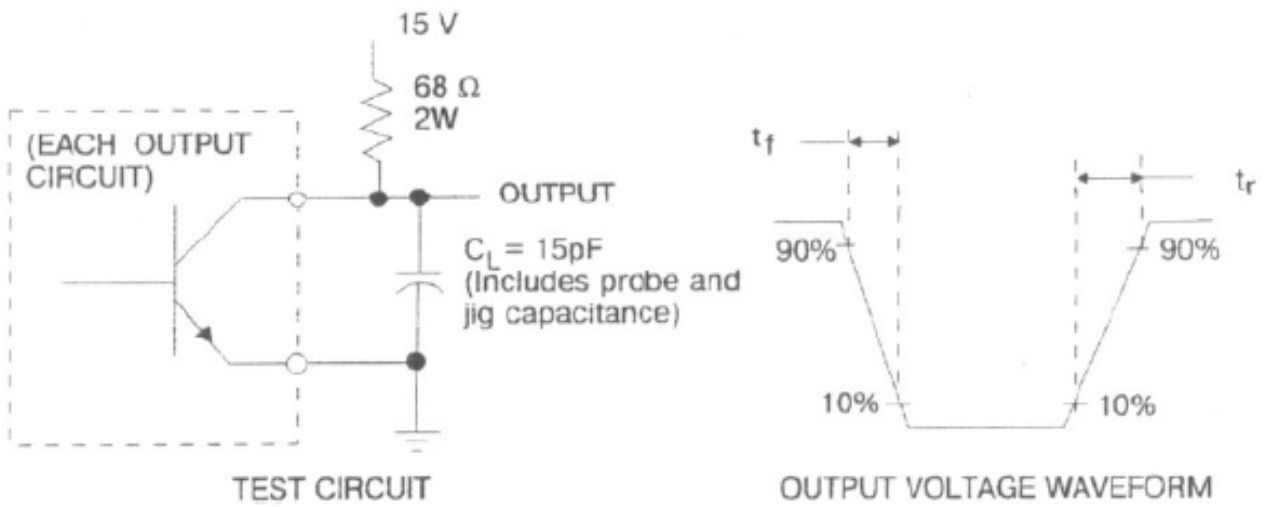

Figure 3. Common - emitter configuration

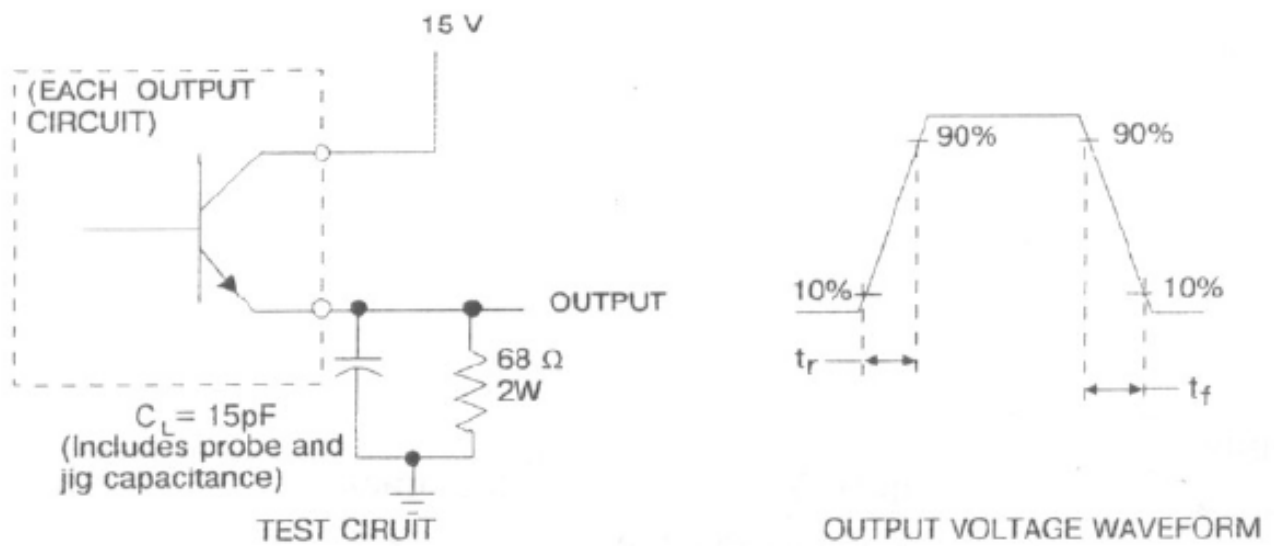
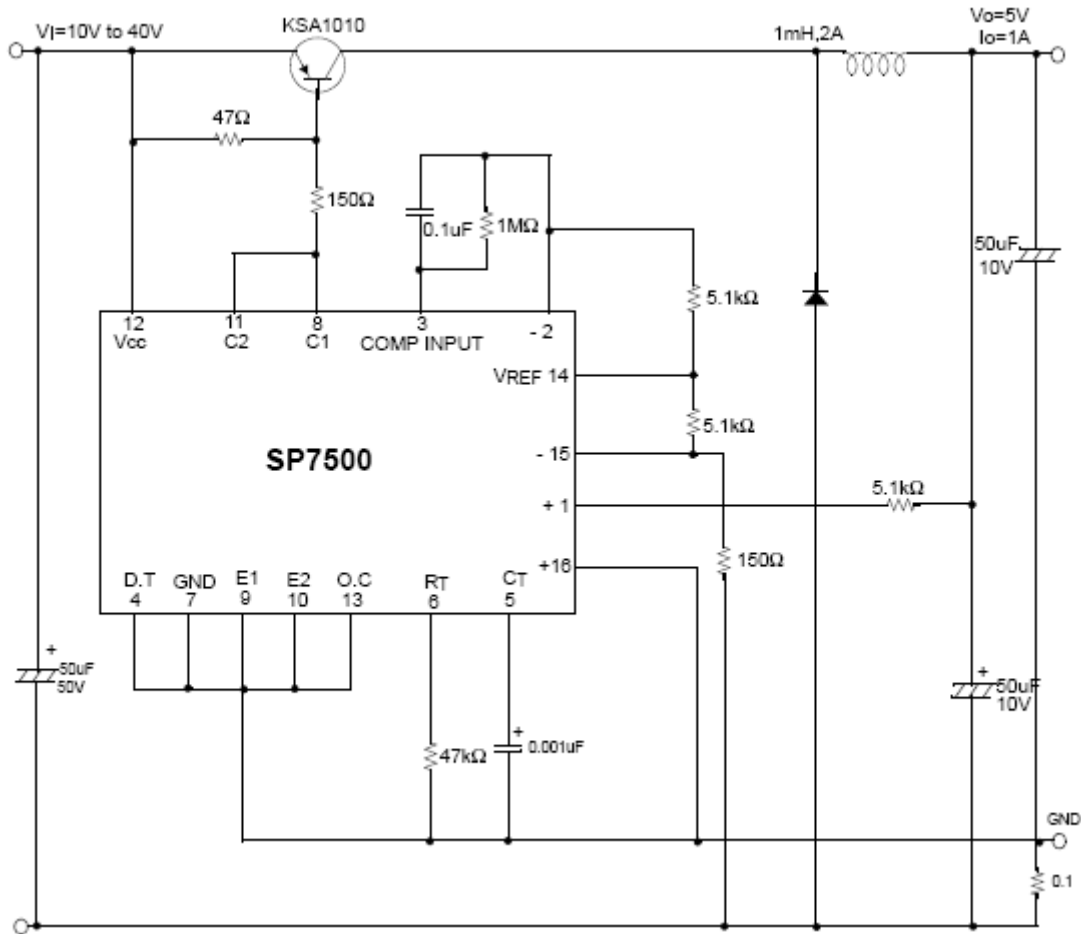

Figure 4. Emitter - follower configuration

Typical Application



Ordering Information

ORDERING NUMBER	PACKAGE	MARKING
SP7500	DIP-16	SP7500

Copyright © 2008 by HOTCHIP TECHNOLOGY CO., LTD.

The information appearing in this Data Sheet is believed to be accurate at the time of publication. However, HOTCHIP assumes no responsibility arising from the use of the specifications described. The applications mentioned herein are used solely for the purpose of illustration and HOTCHIP makes no warranty or representation that such applications will be suitable without further modification, nor recommends the use of its products for application that may present a risk to human life due to malfunction or otherwise. HOTCHIP's products are not authorized for use as critical components in life support devices or systems. HOTCHIP reserves the right to alter its products without prior notification. For the most up-to-date information, please visit our web site at <http://www.hotchip.net.cn>.