

DESCRIPTION

The SP78LXX series of three-terminal positive Regulators employ internal current limiting and Thermal shutdown, making them essentially indestructible. If adequate heat-sink is provided, they can deliver up to 100 mA output current. They are intended as fixed voltage regulators in a wide range of applications including local or on-card regulation for elimination of noise and distribution problems associated with single-point regulation. In addition, they can be used with power pass Elements to make high-current voltage regulators. The SP78LXX series used as Zener diode/ resistor Combination replacement, offers an effective Output impedance improvement of typically two Orders of magnitude, along with lower quiescent Current and lower noise.

FEATURES

- ◆ Output current up to 100 mA
- ◆ Output voltages of 3.3; 5; 8; 9; 12; V
- ◆ Thermal overload protection
- ◆ Short circuit protection
- ◆ No external components are required
- ◆ Output Voltage Accuracy of $\pm 5\%$ over the Full Temperature Range

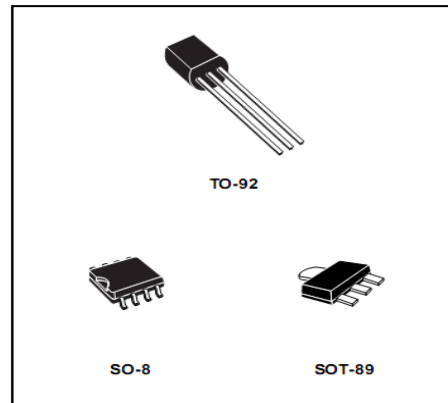

SCHEMATIC DIAGRAM

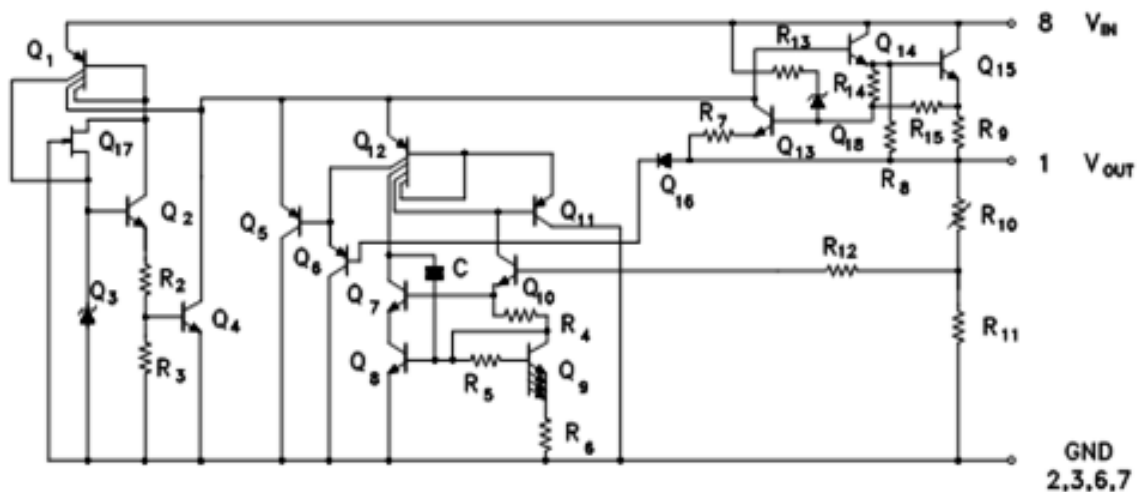

ABSOLUTEMAXIMUMRATINGS

Symbol	Parameter ²		Value	Unit
VI	DC Input Voltage	V _O = 3.3 to 9 V	30	V
		V _O = 12 to 15 V	35	
		V _O = 18 to 24 V	40	
IO	Output Current		100	mA
P _{tot}	Power Dissipation		Internally Limited (*)	
T _{stg}	Storage Temperature Range		-40 to 150	° C
Top	Operating Junction Temperature Range	SP78LXXAC	0 to 125	°C

(*)Our SO-8 package used for Voltage Regulators is modified internally to have pins 2, 3, 6 and 7 electrically communed to the die attach flag. This particular frame decreases the total thermal resistance of the package and increases its ability to dissipate power when an appropriate area of copper on the printed circuit board is available for heat-sinking. The external dimensions are the same as for the standard SO-8.

THERMALDATA

Symbol	Parameter	SO-8	TO-92	SOT-89	Unit
R _{thj-case}	Thermal Resistance Junction-case Max	20		15	°C/W
R _{thj-amb}	Thermal Resistance Junction-ambient Max	55(*)	200		°C/W

(*)Considering 6 cm² copper Board heat-sink

TEST CIRCUITS

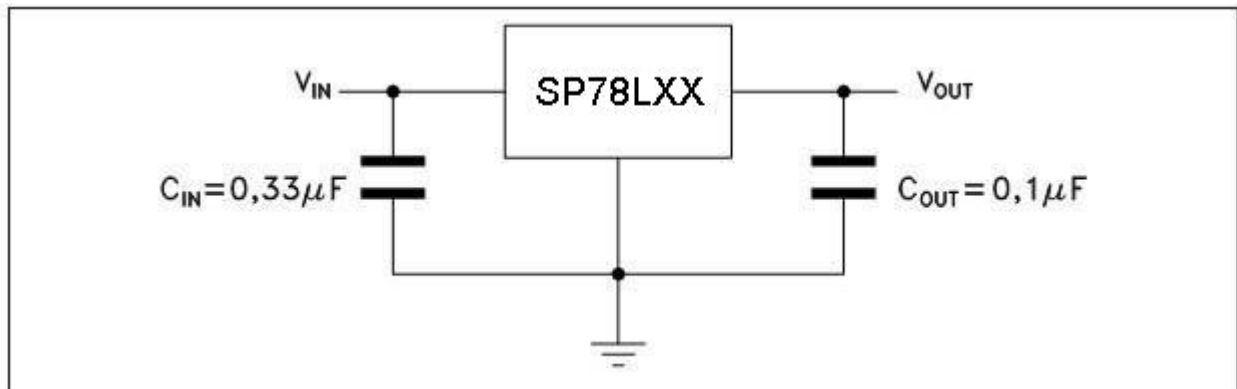

CONNECTION DIAGRAM (top view)

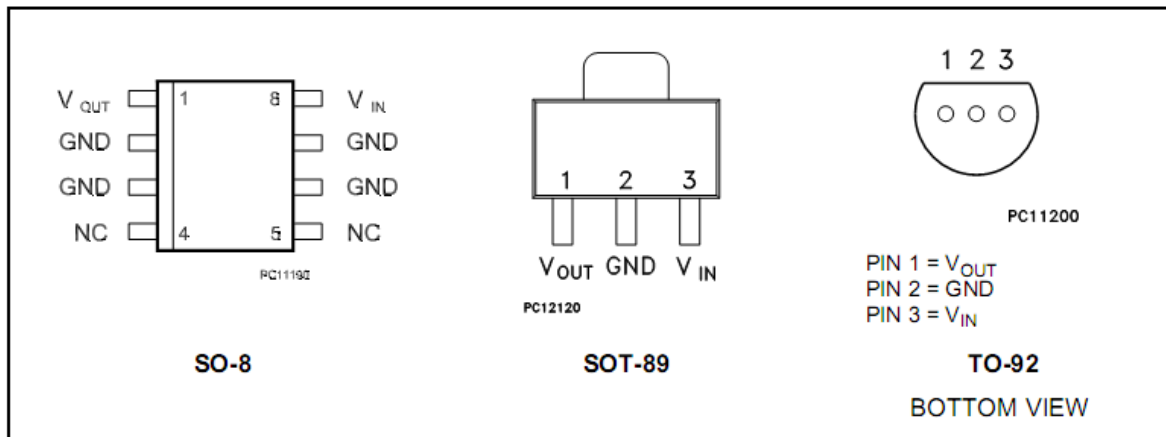

ORDERING CODES

TYPE	SO-8 (TUBE)*	TO-92 (TUBE)**	SOT-89 (T&R)	OUTPUT VOLTAGE
SP78L33AC	SP78L33ACD	SP78L33ACZ	SP78L33ACUTR	3.3 V
SP78L05AC	SP78L05ACD	SP78L05ACZ	SP78L05ACUTR	5 V
SP78L08AC	SP78L08ACD	SP78L08ACZ	SP78L08ACUTR	8 V
SP78L09AC	SP78L09ACD	SP78L09ACZ	SP78L09ACUTR	9 V
SP78L12AC	SP78L12ACD	SP78L12ACZ	SP78L12ACUTR	12 V

(*) Available in Tape & Reel with the suffix "13TR".

(**) Available in Ammopak with the suffix "-AP" or in Tape & Reel with the suffix "TR".

ELECTRICAL CHARACTERISTICS OF SP78L33AC (refer to the test circuits, $V_I=8.3V, I_O=40mA, C_I=0.33\mu F, C_O=0.1\mu F, T=0$ to $125^\circ C$ for SP78L33AC, $T=-40$ to $125^\circ C$, unless otherwise specified)

Symbol	Parameter	Test Conditions	Min.	Typ.	Max.	Unit
V_O	Output Voltage	$T_J = 25^\circ C$	3.168	3.3	3.43 2	V
V_O	Output Voltage	$I_O = 1$ to 40 mA $V_I = 5.3$ to 20 V	3.135		3.46 5	V
		$I_O = 1$ to 70 mA $V_I = 8.3$ V	3.135		3.46 5	V
ΔV_O	Line Regulation	$V_I = 5.3$ to 20 V $T_J = 25^\circ C$			150	mV
		$V_I = 6.3$ to 20 V $T_J = 25^\circ C$			100	mV
ΔV_O	Load Regulation	$I_O = 1$ to 100 mA $T_J = 25^\circ C$			60	mV
		$I_O = 1$ to 40 mA $T_J = 25^\circ C$			30	mV
I_d	Quiescent Current	$T_J = 25^\circ C$			6	mA
		$T_J = 125^\circ C$			5.5	mA
ΔI_d	Quiescent Current Change	$I_O = 1$ to 40 mA			0.1	mA
		$V_I = 6.3$ to 20 V			1.5	mV
eN	Output Noise Voltage	$B = 10$ Hz to 100 KHz $T_J = 25^\circ C$		40		μV
SVR	Supply Voltage Rejection	$V_I = 6.3$ to 16.3 V $f = 120$ Hz $I_O = 40$ mA $T_J = 25^\circ C$	41	49		dB
V_d	Dropout Voltage			1.7		V

ELECTRICAL CHARACTERISTICS OF SP78L05AC (refer to the test circuits, $V_I = 10V$, $I_O = 40mA$, $C_I = 0.33\mu F$, $C_O = 0.1\mu F$, $T_J = 0$ to $125^\circ C$ for SP78L05AC, unless otherwise specified)

Symbol	Parameter	Test Conditions	Min.	Typ.	Max.	Unit
V_O	Output Voltage	$T_J = 25^\circ C$	4.8	5	5.2	V
V_O	Output Voltage	$I_O = 1$ to 40 mA $V_I = 7$ to 20 V	4.75		5.25	V
		$I_O = 1$ to 70 mA $V_I = 10$ V	4.75		5.25	
ΔV_O	Line Regulation	$V_I = 7$ to 20 V $T_J = 25^\circ C$			150	mV
		$V_I = 8$ to 20 V $T_J = 25^\circ C$			100	
ΔV_O	Load Regulation	$I_O = 1$ to 100 mA $T_J = 25^\circ C$			60	mV
		$I_O = 1$ to 40 mA $T_J = 25^\circ C$			30	
I_d	Quiescent Current	$T_J = 25^\circ C$			6	mA
		$T_J = 125^\circ C$			5.5	mA
ΔI_d	Quiescent Current Change	$I_O = 1$ to 40 mA			0.1	mA
		$V_I = 8$ to 20 V			1.5	
eN	Output Noise Voltage	$B = 10$ Hz to 100 KHz $T_J = 25^\circ C$		40		μV
SVR	Supply Voltage Rejection	$V_I = 8$ to 18 V $f = 120$ Hz $I_O = 40$ mA $T_J = 25^\circ C$	41	49		dB
V_d	Dropout Voltage			1.7		V

ELECTRICAL CHARACTERISTICS OF SP78L08AC (refer to the test circuits, $V_I = 14V$, $I_O = 40mA$, $C_I = 0.33\mu F$, $C_O = 0.1\mu F$, $T = 0$ to $125^\circ C$ for SP78L08AC, unless otherwise specified)

Symbol	Parameter	Test Conditions	Min.	Typ.	Max.	Unit
V_O	Output Voltage	$T_J = 25^\circ C$	7.68	8	8.32	V
V_O	Output Voltage	$I_O = 1$ to 40 mA $V_I = 10.5$ to 23 V	7.6		8.4	V
		$I_O = 1$ to 70 mA $V_I = 14$ V	7.6		8.4	
ΔV_O	Line Regulation	$V_I = 10.5$ to 23 V $T_J = 25^\circ C$			175	mV
		$V_I = 11$ to 23 V $T_J = 25^\circ C$			125	
ΔV_O	Load Regulation	$I_O = 1$ to 100 mA $T_J = 25^\circ C$			80	mV
		$I_O = 1$ to 40 mA $T_J = 25^\circ C$			40	
I_d	Quiescent Current	$T_J = 25^\circ C$			6	mA
		$T_J = 125^\circ C$			5.5	mA
ΔI_d	Quiescent Current Change	$I_O = 1$ to 40 mA			0.1	mA
		$V_I = 11$ to 23 V			1.5	
eN	Output Noise Voltage	$B = 10$ Hz to 100 KHz $T_J = 25^\circ C$		60		μV
SVR	Supply Voltage Rejection	$V_I = 12$ to 23 V $f = 120$ Hz $I_O = 40$ mA $T_J = 25^\circ C$	37	45		dB
V_d	Dropout Voltage			1.7		V

ELECTRICAL CHARACTERISTICS OF SP78L09AC

(refer to the test circuits, $V_I = 15V$, $I_O = 40mA$, $C_I = 0.33\mu F$, $C_O = 0.1\mu F$, $T_J = 0$ to $125^\circ C$ for SP78L09AC, unless otherwise specified)

Symbol	Parameter	Test Conditions	Min.	Typ.	Max.	Unit
V_O	Output Voltage	$T_J = 25^\circ\text{C}$	8.64	9	9.36	V
V_O	Output Voltage	$I_O = 1 \text{ to } 40 \text{ mA } V_I = 11.5 \text{ to } 23 \text{ V}$	8.55		9.45	V
		$I_O = 1 \text{ to } 70 \text{ mA } V_I = 15 \text{ V}$	8.55		9.45	
ΔV_O	Line Regulation	$V_I = 11.5 \text{ to } 23 \text{ V } T_J = 25^\circ\text{C}$			225	mV
		$V_I = 12 \text{ to } 23 \text{ V } T_J = 25^\circ\text{C}$			150	
ΔV_O	Load Regulation	$I_O = 1 \text{ to } 100 \text{ mA } T_J = 25^\circ\text{C}$			80	mV
		$I_O = 1 \text{ to } 40 \text{ mA } T_J = 25^\circ\text{C}$			40	
I_d	Quiescent Current	$T_J = 25^\circ\text{C}$			6	mA
		$T_J = 125^\circ\text{C}$			5.5	mA
ΔI_d	Quiescent Current Change	$I_O = 1 \text{ to } 40 \text{ mA}$			0.1	mA
		$V_I = 12 \text{ to } 23 \text{ V}$			1.5	
eN	Output Noise Voltage	$B = 10 \text{ Hz to } 100 \text{ kHz } T_J = 25^\circ\text{C}$		70		μV
SVR	Supply Voltage Rejection	$V_I = 12 \text{ to } 23 \text{ V } f = 120 \text{ Hz}$ $I_O = 40 \text{ mA } T_J = 25^\circ\text{C}$	37	44		dB
V_d	Dropout Voltage			1.7		V

ELECTRICAL CHARACTERISTICS OF SP78L12AC

(refer to the test circuits, $V_I = 19 \text{ V}$, $I_O = 40 \text{ mA}$, $C_I = 0.33 \mu\text{F}$, $C_O = 0.1 \mu\text{F}$, $T_J = 0 \text{ to } 125^\circ\text{C}$ for SP78L12AC, unless otherwise specified)

Symbol	Parameter	Test Conditions	Min.	Typ.	Max.	Unit
V_O	Output Voltage	$T_J = 25^\circ\text{C}$	11.5	12	12.5	V
V_O	Output Voltage	$I_O = 1 \text{ to } 40 \text{ mA } V_I = 14.5 \text{ to } 27 \text{ V}$	11.4		12.6	V
		$I_O = 1 \text{ to } 70 \text{ mA } V_I = 19 \text{ V}$	11.4		12.6	
ΔV_O	Line Regulation	$V_I = 14.5 \text{ to } 27 \text{ V } T_J = 25^\circ\text{C}$			250	mV
		$V_I = 16 \text{ to } 27 \text{ V } T_J = 25^\circ\text{C}$			200	
ΔV_O	Load Regulation	$I_O = 1 \text{ to } 100 \text{ mA } T_J = 25^\circ\text{C}$			100	mV
		$I_O = 1 \text{ to } 40 \text{ mA } T_J = 25^\circ\text{C}$			50	
I_d	Quiescent Current	$T_J = 25^\circ\text{C}$			6.5	mA
		$T_J = 125^\circ\text{C}$			6	mA
ΔI_d	Quiescent Current Change	$I_O = 1 \text{ to } 40 \text{ mA}$			0.1	mA
		$V_I = 16 \text{ to } 27 \text{ V}$			1.5	
eN	Output Noise Voltage	$B = 10 \text{ Hz to } 100 \text{ kHz } T_J = 25^\circ\text{C}$		80		μV
SVR	Supply Voltage Rejection	$V_I = 15 \text{ to } 25 \text{ V } f = 120 \text{ Hz } I_O = 40 \text{ mA } T_J = 25^\circ\text{C}$	37	42		dB
V_d	Dropout Voltage			1.7		V

SP78LXX SERIES

Figure1: SP78L05/08 Output Voltage vs Ambient Temperature

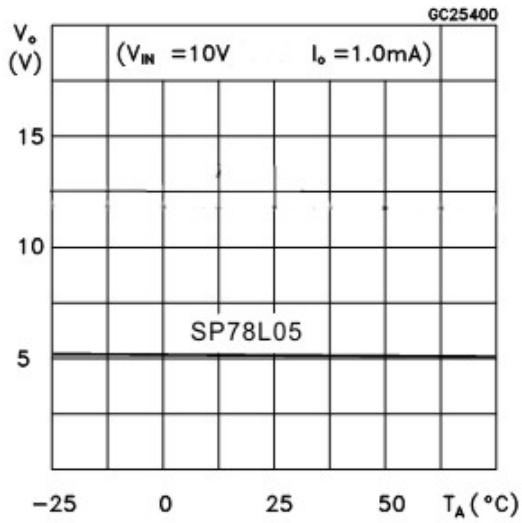

Figure2: SP78L05/12/24 Load Characteristics

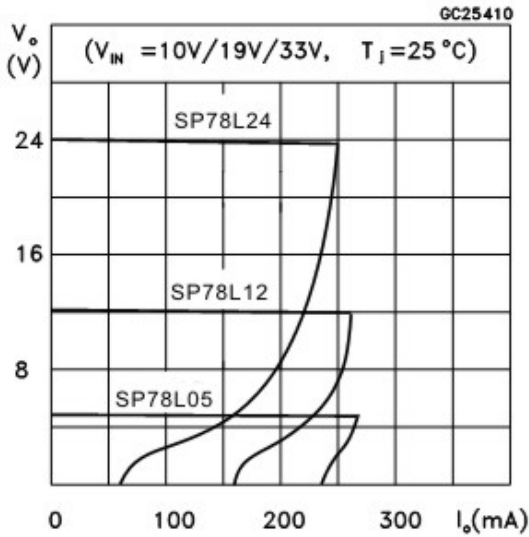

Figure3: SP78L05/12/24 Thermal Shutdown

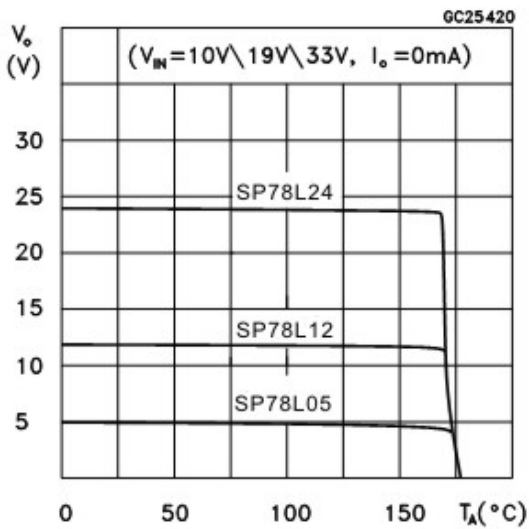

Figure4: SP78L05/08 Quiescent Current vs Output Current

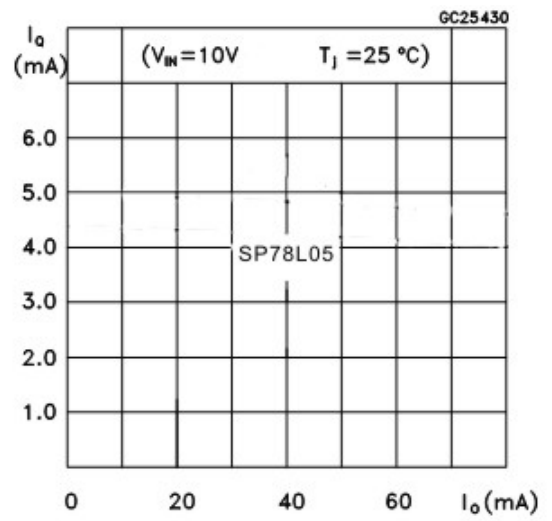

Figure5: SP78L05 Quiescent Current vs Input Voltage

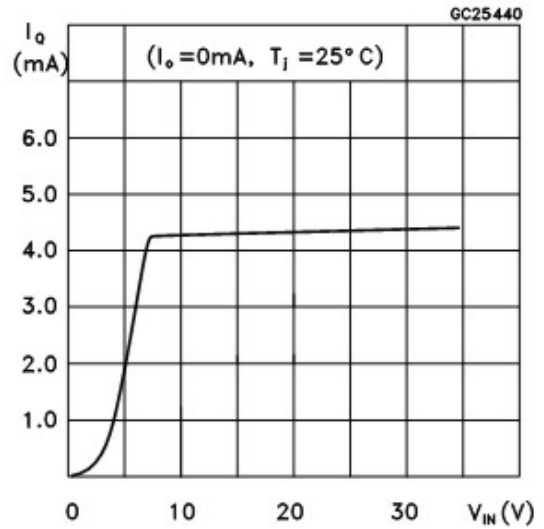
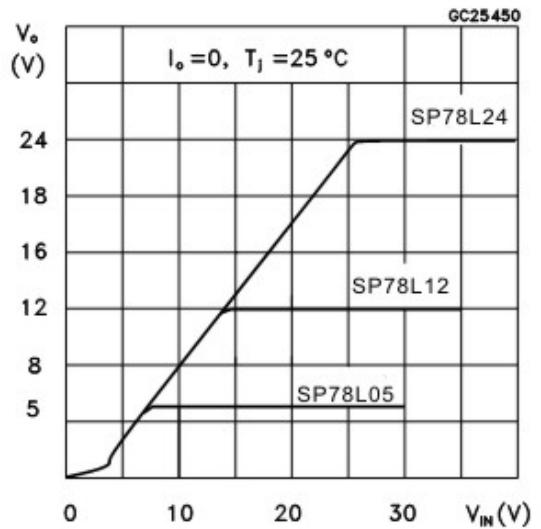

Figure6: SP78L05/12/24 Output Characteristics



SP78LXX SERIES

Figure7: SP78L05/12/24 Ripple Rejection

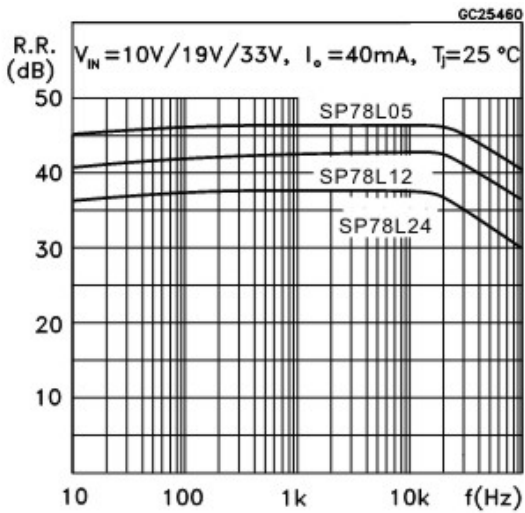

Figure8: SP78L05 Dropout Characteristics

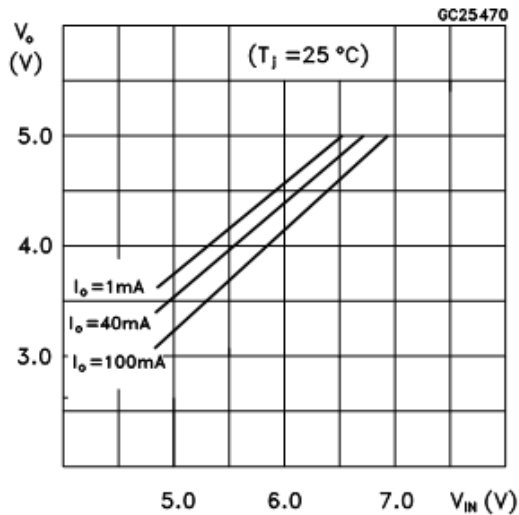
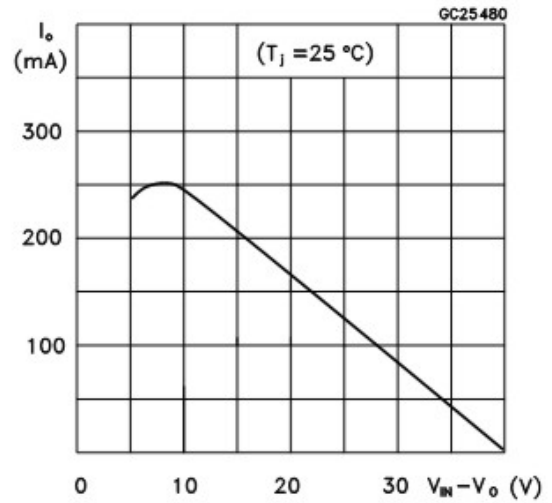

Figure9: SP78LXX Series Short Circuit Output Current



TYPICAL APPLICATIONS

Table10: High Output Current Short Circuit Protected

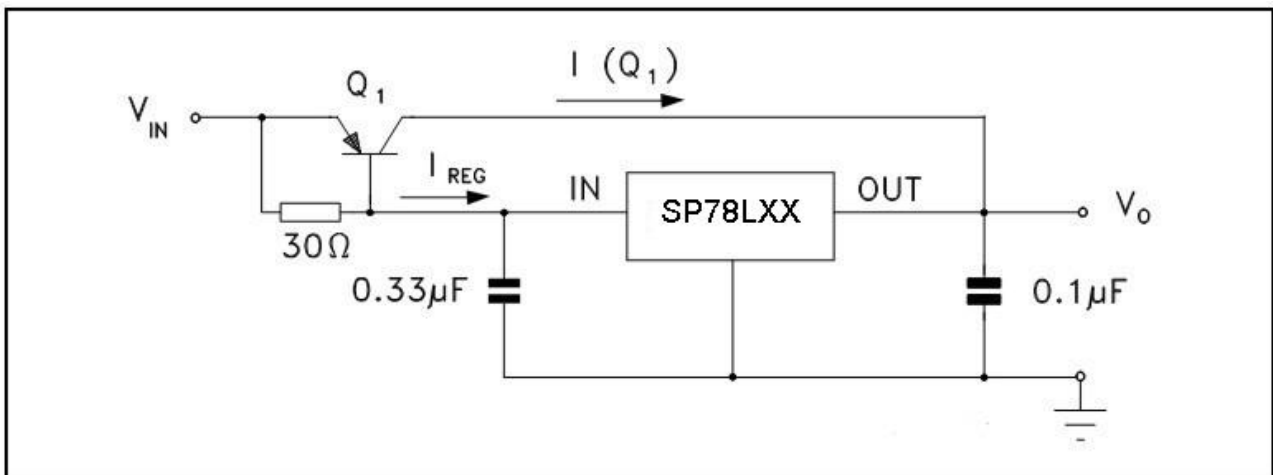

Figure11: Edit Boost Circuit

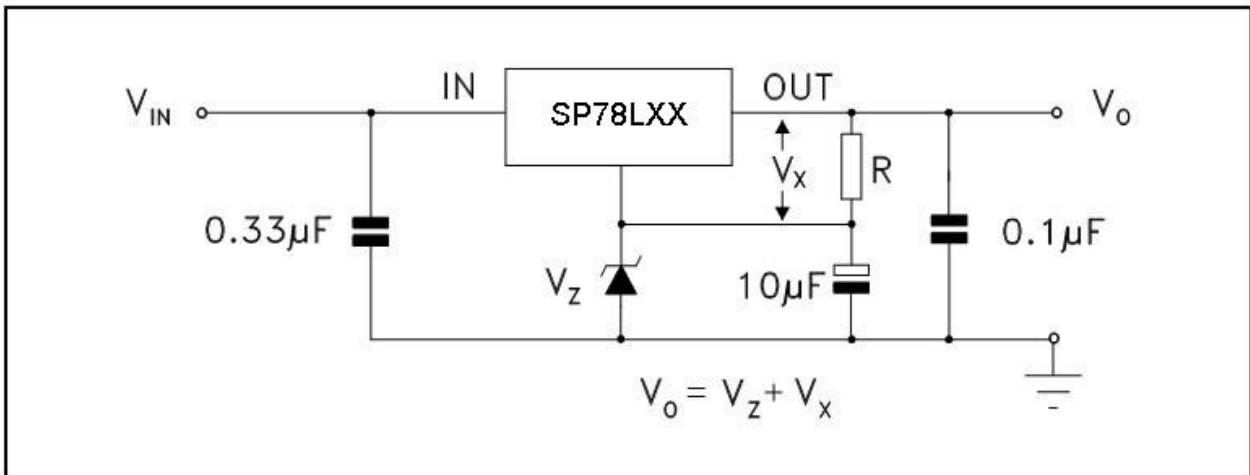

Figure12: Current Regulator

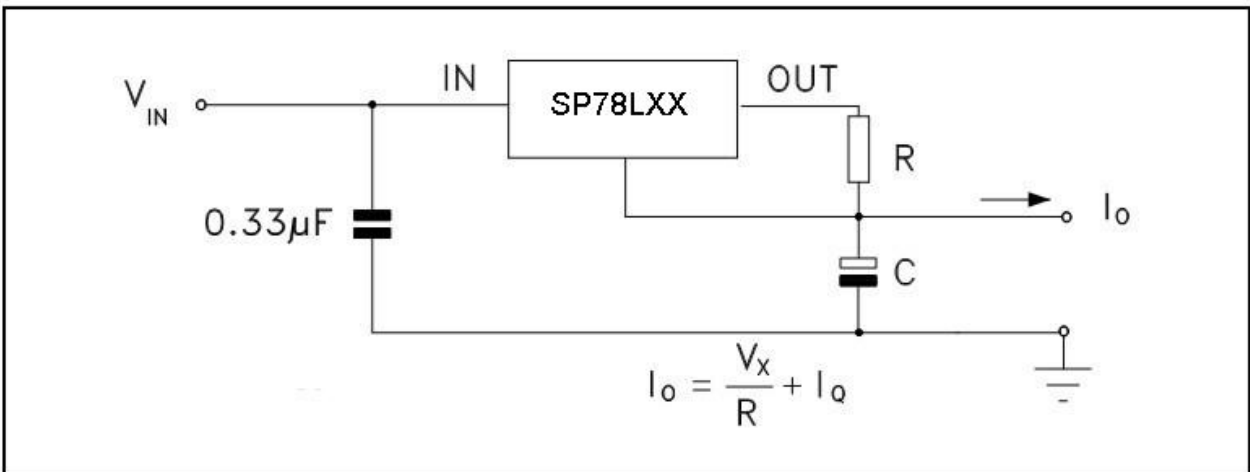
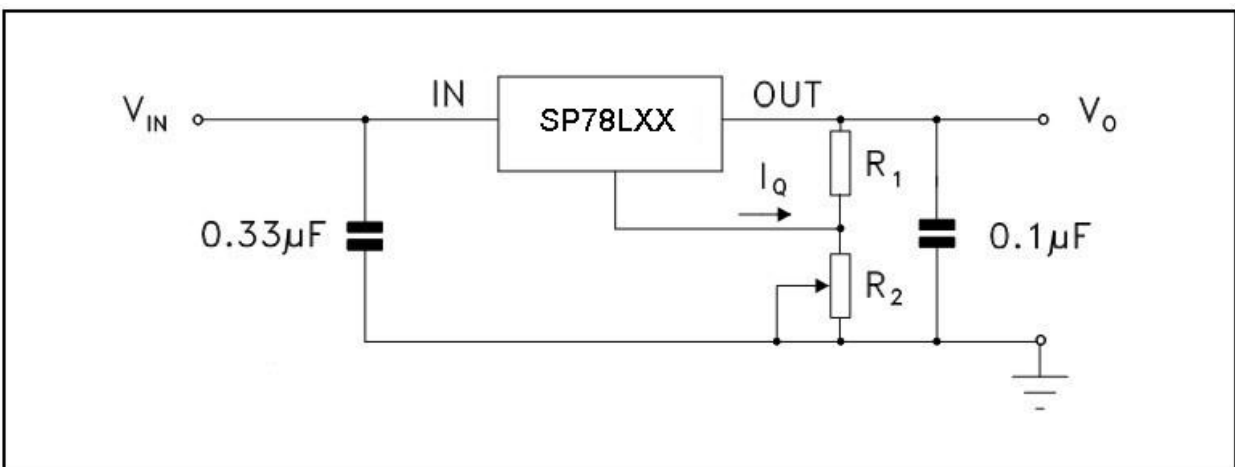
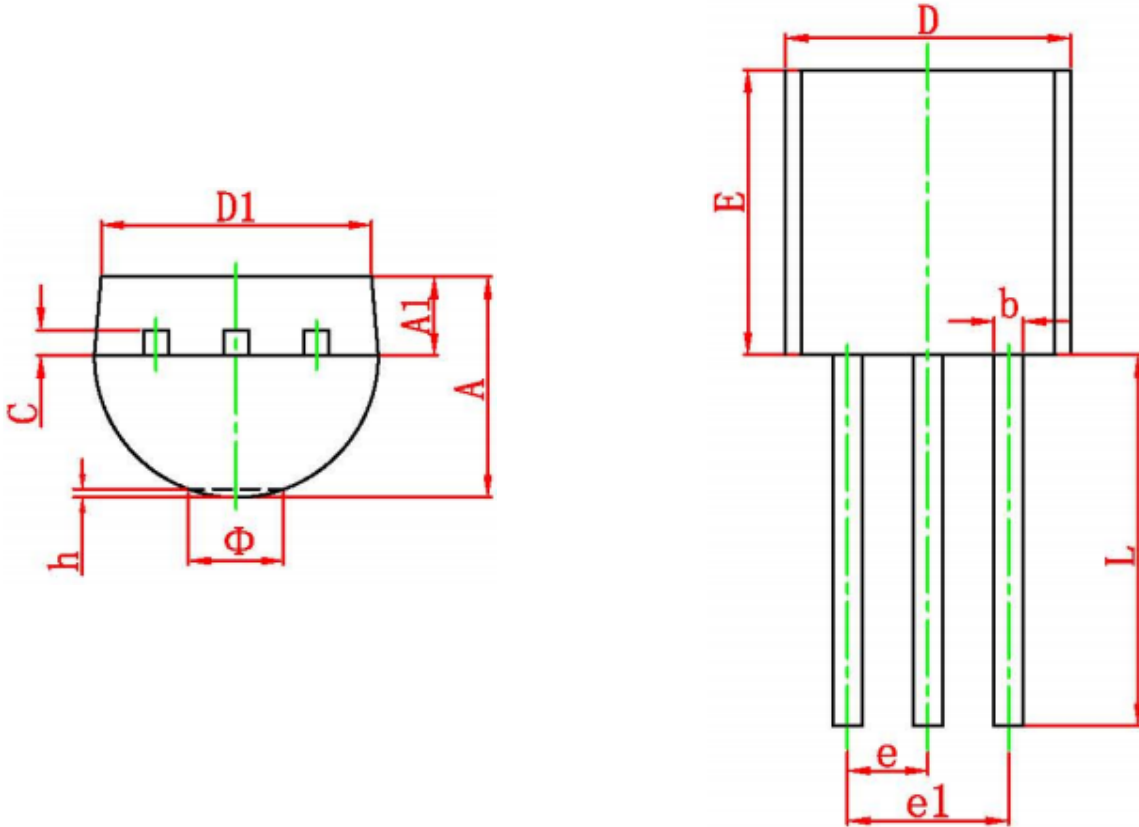

Figure13: Adjust able Output Regulator



PACKAGE DESCRIPTION

TO-92 PACKAGE OUTLINE DIMENSIONS



Symbol	Dimensions In Millimeters		Dimensions In Inches	
	Min	Max	Min	Max
A	3.300	3.700	0.130	0.148
A1	1.100	1.400	0.043	0.055
b	0.380	0.550	0.015	0.022
c	0.360	0.510	0.014	0.020
D	4.400	4.700	0.173	0.185
D1	3.430		0.135	
E	4.300	4.700	0.169	0.185
e	1.270TYP		0.050TYP	
e1	2.440	2.640	0.096	0.104
L	14.100	14.500	0.555	0.5721
		1.600		0.063
h	0.000	0.380	0.000	0.015

SOT-89-3L package outline dimensions

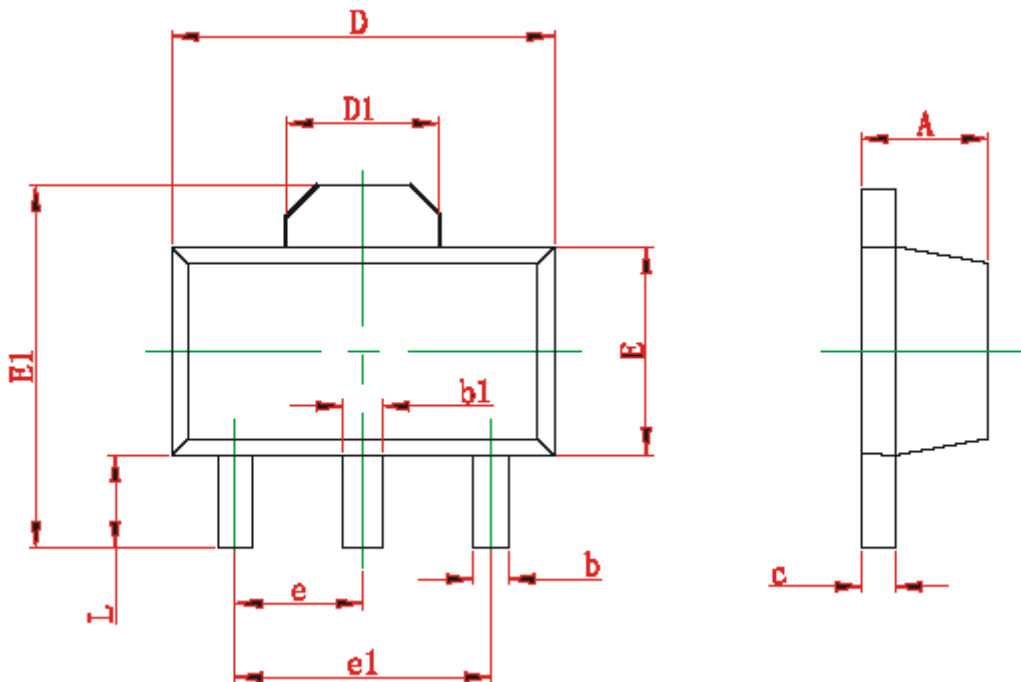

Symbol	Dimensions In Millimeters		Dimensions In Inches	
	Min	Max	Min	Max
A	1.400	1.600	0.055	0.063
b	0.320	0.520	0.013	0.197
b1	0.400	0.580	0.016	0.023
c	0.350	0.440	0.014	0.017
D	4.400	4.600	0.173	0.181
D1	1.550REF		0.061REF	
E	2.300	2.600	0.091	0.102
E1	3.940	4.250	0.155	0.167
e	1.500TYP		0.060TYP	
e1	3.000TYP		0.118TYP	
L	0.900	1.200	0.035	0.047

SOP8 package outline dimensions

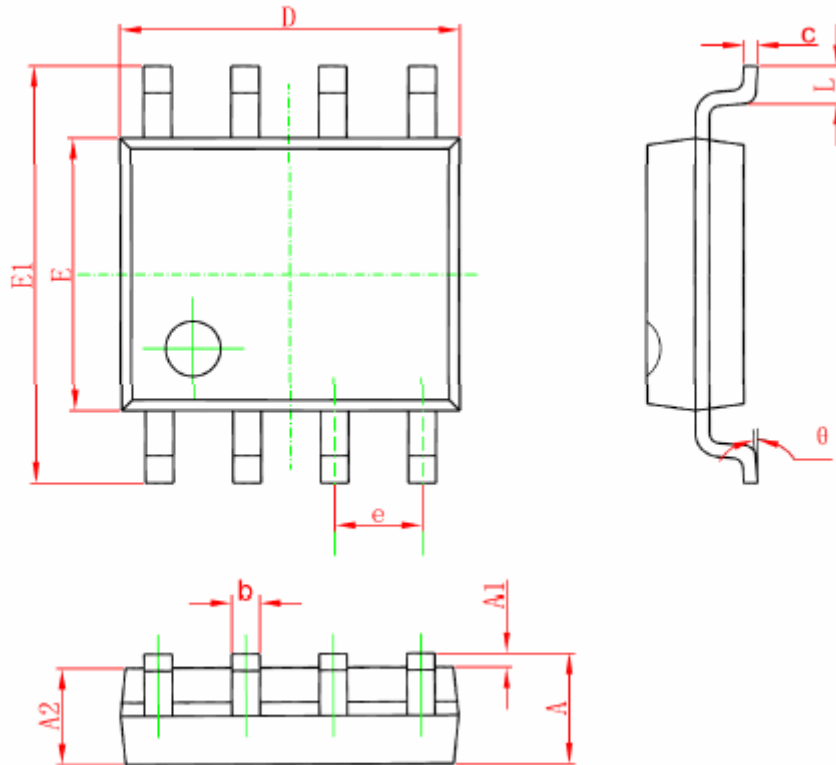

Symbol	Dimensions In Millimeters		Dimensions In Inches	
	Min	Max	Min	Max
A	1.350	1.750	0.053	0.069
A1	0.100	0.250	0.004	0.010
A2	1.350	1.550	0.053	0.061
b	0.330	0.510	0.013	0.020
c	0.170	0.250	0.006	0.010
D	4.700	5.100	0.185	0.200
E	3.800	4.000	0.150	0.157
E1	5.800	6.200	0.228	0.244
e	1.270 (BSC)		0.050 (BSC)	
L	0.400	1.270	0.016	0.050
θ	0°	8°	0°	8°

Copyright © 2008 by HOTCHIP TECHNOLOGY CO., LTD.

The information appearing in this Data Sheet is believed to be accurate at the time of publication. However, HOTCHIP assumes no responsibility on the use of the specifications described. The applications mentioned herein are used solely for the purpose of illustration and HOTCHIP makes no warranty or representation that such applications will be suitable without further modification, nor recommends the use of its products for application that may present a risk to human life due to malfunction or otherwise. HOTCHIP's products are not authorized for use as critical components in life support devices or systems. HOTCHIP reserves the right to alter its products without prior notification. For the most up-to-date information, please visit our web site at <http://www.hotchip.net.cn>.