

GENERAL DESCRIPTION

The LM317 are adjustable three - terminal positive -voltage regulators capable of supplying 1.5A over a differential voltage range of 3V to 40V. They are exceptionally easy to use and require only two external resistors to set the output voltage. Both input and output regulation are better than standard fixed regulators. In addition to higher performance than fixed regulators, these regulators offer full overload protection available only in integrated circuits. Included on the chip are current limit, thermal overload protection, and safe-area protection. All overload protection circuitry remains fully functional even if the adjustment terminal no capacitors are needed unless the device is situated far from the input filter capacitors in which case an input bypass is needed. An optional output capacitor can be added to improve transient response. The primary applications of each of these regulators is that of a programmable output regulator, but by connecting a fixed resistor between adjustment terminal and the output terminal, each device can be used as a precision current regulator. Even though the regulator is floating and sees only the input-to-output differential voltage, use of these devices to regulate output voltages that would cause the

maximum-rated differential voltage to be exceeded if the output became shorted to ground is not recommended.

FEATURES

- ◆ Output Voltage Range Adjustable from 1.2 V to 37 V.
- ◆ Output Current Capability of 1.5 A Max.
- ◆ Input Regulation Typically 0.01 % Per Input - Volt Change.
- ◆ Output Regulation Typically 0.1 %..
- ◆ Peak Output Current Constant Over Temperature Range of Regulator.
- ◆ Popular 3-Lead TO-220 Package
- ◆ Ripple Rejection Typically 80 dB.

Pin Description

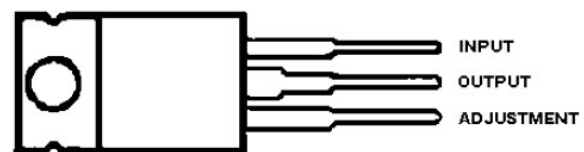

The output terminal is in electrical contact with the mounting base

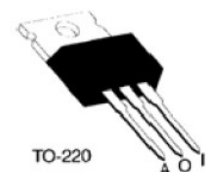

Typical Application Data

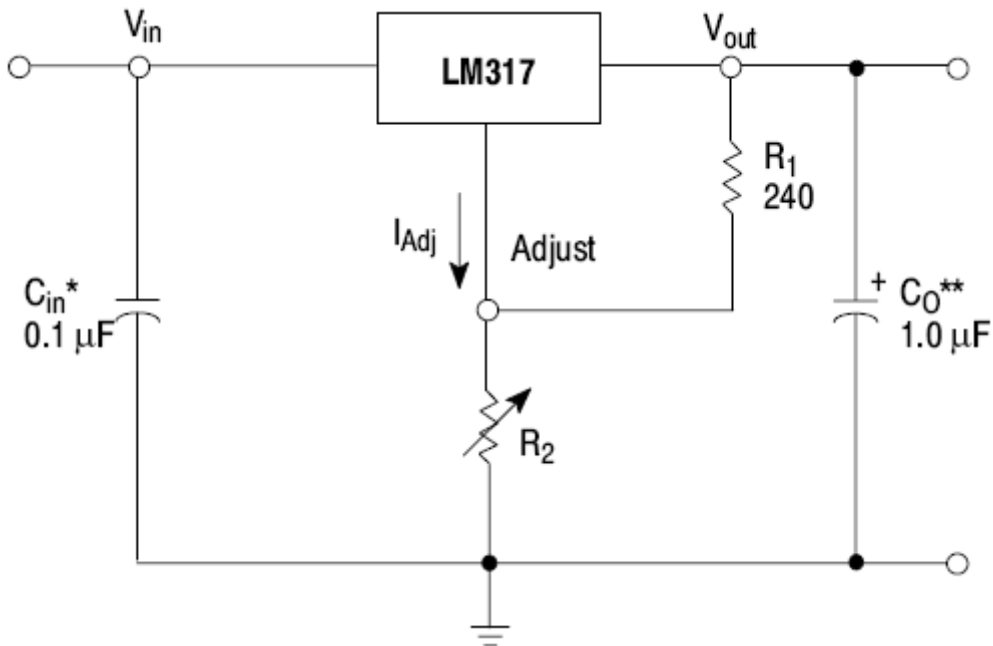

Note A: Use of an input bypass capacitor is recommended if regulator is far from filter capacitors.

Note B: Use of an output capacitor improves transient response but is optional.

Note C: Output voltage is calculated from the equation: $V_O = V_{REF} \left(1 + \frac{R_2}{R_1}\right) + I_{ADJ} R_2$

Vref equals the difference between the output and adjustment terminal

Absolute Maximum Ratings

OVER OPERATING TEMPERATURE RANGE (UNLESS OTHERWISE NOTED)

Parameter	Maximum	Units
Input-to-output differential voltage, VI - Vo	40	V
Continuous total dissipation at 25 ° C free-air temperature	2	W
Continuous total dissipation at (or below) 25 ° C case temperature	15	W
Operating free-air, case, or virtual junction temperature range	0 to 125	° C
Storage temperature range	-65 to 150	° C

Recommended Operating Conditions

Parameter	LM 317		Units
	min	max	
Output current, I_o	10	1500	mA
Operating virtual junction temperature, T_J	0	125	° C

Electrical Characteristics

Electrical Characteristics over recommended ranges of operating virtual junction temperature (unless otherwise noted) (Note 1)

Parameter	Test Conditions*		LM317			Units
Input regulation (Note 2)	$V_I - V_O = 3\text{ V to } 40\text{ V}$, (Note 3)	$T_J = \text{MIN to MAX}$	Min	Typ	Max	
		$I_o = 10\text{ mA to } 1.5\text{ A}$		0.01	0.04	%/ V
Ripple rejection	$V_o = 10\text{ V}$, $f = 120\text{ Hz}$			0.02	0.07	
	$V_o = 10\text{ V}$, $f = 120\text{ Hz}$			65		dB
	10- μ F capacitor between ADJ and ground		66	80		
Output regulation	$I_o = 10\text{ mA to } 1.5\text{ A}$, $T_J = 25^\circ\text{ C}$, (See Note 3)	$V_o \leq 5\text{ V}$		5	25	mV
		$V_o > 5\text{ V}$		0.1	0.5	%
	$I_o = 10\text{ mA to } 1.5\text{ A}$, (Note 3)	$V_o \leq 5\text{ V}$		20	70	mV
		$V_o > 5\text{ V}$		0.3	1.5	%
Output voltage change with temperature	$T_J = \text{MIN to MAX}$			1		%
Output voltage long-term drift (Note 4)	After 1000 h at $T_J = \text{MAX}$ and $V_I - V_o = 40\text{ V}$			0.3	1	%
Output noise voltage	$f = 10\text{ Hz to } 10\text{ kHz}$, $T_J = 25^\circ$			0.003		%
Minimum output current to maintain regulation	$V_I - V_o = 40\text{ V}$			3.5	10	mA
Peak output current	$V_I - V_o \leq 15\text{ V}$		1.5	2.2		A
	$V_I - V_o \leq 40\text{ V}$, $T_J = 25^\circ$		0.1 5	0.4		
Adjustment-terminal current				60	100	$\mu\text{ A}$
Change in adjustment-terminal current	$V_I - V_o = 2.5\text{ V to } 40\text{ V}$, $I_o = 10\text{ mA to } 1.5\text{ A}$			0.2	5.0	$\mu\text{ A}$
Reference voltage (output to ADJ)	$V_I - V_o = 3\text{ V to } 40\text{ V}$, $I_o = 10\text{ mA to } 1.5\text{ A}$, $P \leq 15\text{ W}$		1.2	1.25	1.3	V

* Unless otherwise noted, these specifications apply for the following test conditions: $V_I - V_O = 5V$ and $I_O = 0.5 A$. For conditions shown as MIN or MAX, use the appropriate value specified under recommended operating conditions.

Note 1: All characteristics are measured with a $0.1 - \mu F$ capacitor across the input and a $1 - \mu F$ capacitor across the output.

Note 2: Input regulation is expressed here as the percentage change in output voltage per 1 - V change at the input.

Note 3: Pulse testing techniques are used to maintain the junction temperature as close to the ambient temperature as possible. Thermal effects must be taken into account separately.

Note 4: Since long-term drift cannot be measured on the individual devices prior to shipment, this specification is not intended to be a guarantee or warranty. It is an engineering estimate of the average drift to be expected from lot to lot.

Ordering Information

ORDERING NUMBER	PACKAGE	MARKING
LM317	TO - 220	LM317

Package Description

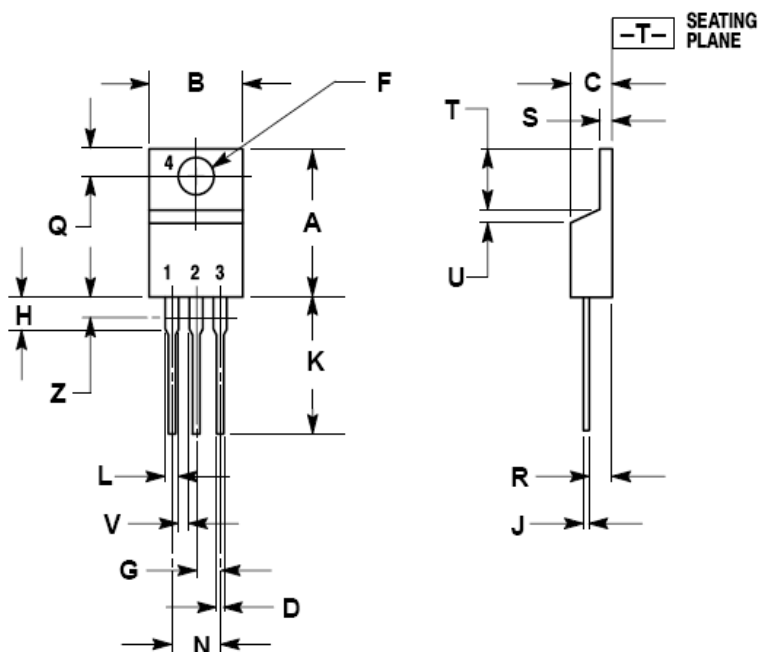

DIM	INCHES		MILLIMETERS	
	MIN	MAX	MIN	MAX
A	0.570	0.620	14.48	15.75
B	0.380	0.405	9.66	10.28
C	0.160	0.190	4.07	4.82
D	0.025	0.035	0.64	0.88
F	0.142	0.147	3.61	3.73
G	0.095	0.105	2.42	2.66
H	0.110	0.155	2.80	3.93
J	0.018	0.025	0.46	0.64
K	0.500	0.562	12.70	14.27
L	0.045	0.060	1.15	1.52
N	0.190	0.210	4.83	5.33
Q	0.100	0.120	2.54	3.04
R	0.080	0.110	2.04	2.79
S	0.045	0.055	1.15	1.39
T	0.235	0.255	5.97	6.47
U	0.000	0.050	0.00	1.27
V	0.045	---	1.15	---
Z	---	0.080	---	2.04

Copyright © 2008 by HOTCHIP TECHNOLOGY CO., LTD.

The information appearing in this Data Sheet is believed to be accurate at the time of publication. However, HOTCHIP assumes no responsibility arising from the use of the specifications described. The applications mentioned herein are used solely for the purpose of illustration and HOTCHIP makes no warranty or representation that such applications will be suitable without further modification, nor recommends the use of its products for application that may present a risk to human life due to malfunction or otherwise. HOTCHIP's products are not authorized for use as critical components in life support devices or systems. HOTCHIP reserves the right to alter its products without prior notification. For the most up-to-date information, please visit our web site at <http://www.hotchip.net.cn>.