

FEATURES

- Diffused Junction
- Ultra-Fast Switching for High Efficiency
- High Current Capability and Low Forward Voltage Drop
- Low Reverse Leakage Current
- Surge Overload Rating to 30A Peak
- Low Reverse Leakage Current
- Plastic Material: UL Flammability Classification Rating 94V-0

Mechanical Data

- Case: Molded Plastic
- Terminals: Plated Leads Solderable per MIL-STD-202, Method 208
- Polarity: Cathode Band
- Marking: Type Number
- Weight: 0.35 grams (approx.)
- Mounting Position: Any

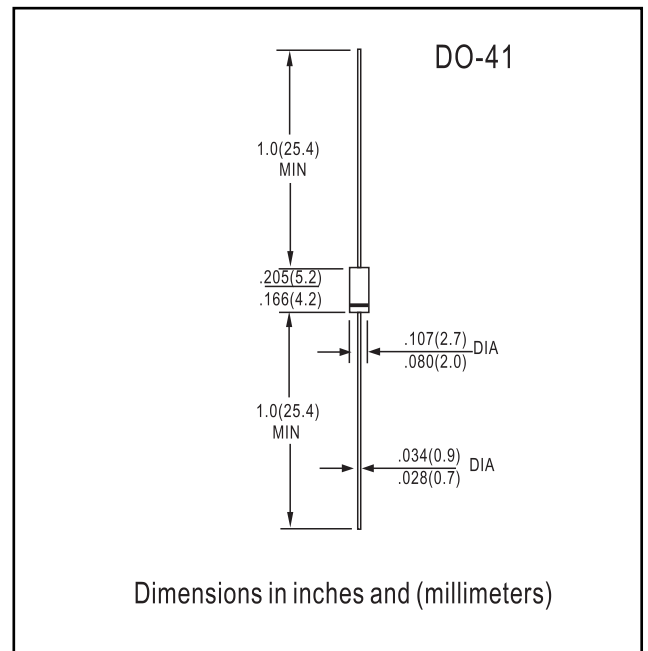

MAXIMUM RATINGS AND ELECTRICAL CHARACTERISTICS

Single phase, half wave, 60Hz, resistive or inductive load.
For capacitive load, derate current by 20%.

Characteristic	Symbol	UF 1001	UF 1002	UF 1003	UF 1004	UF 1005	UF 1006	UF 1007	Unit
Peak Repetitive Reverse Voltage	V_{RRM}	50	100	200	400	600	800	1000	V
Working Peak Reverse Voltage	V_{RWM}								
DC Blocking Voltage	V_R								
RMS Reverse Voltage	$V_{R(RMS)}$	35	70	140	280	420	560	700	V
Average Rectified Output Current (Note 1)	I_O	1.0							A
Non-Repetitive Peak Forward Surge Current 8.3ms Single half sine-wave Superimposed on Rated Load (JEDEC Method)	I_{FSM}	30							A
Forward Voltage @ $I_F = 1.0A$	V_{FM}	1.0		1.3		1.7		V	
Peak Reverse Current at Rated DC Blocking Voltage @ $T_A = 25^\circ C$ @ $T_A = 100^\circ C$	I_{RM}	5.0 100							μA
Reverse Recovery Time (Note 3)	t_{rr}	50				75			ns
Typical Junction Capacitance (Note 2)	C_j	20				10			pF
Typical Thermal Resistance Junction to Ambient	$R_{\theta JA}$	95							K/W
Operating and Storage Temperature Range	T_j, T_{STG}	-65 to +150							$^\circ C$

- Notes:
1. Valid provided that leads are maintained at ambient temperature at a distance of 9.5mm from the case.
 2. Measured at 1.0MHz and applied reverse voltage of 4.0V DC.
 3. Measured with $I_F = 0.5A$, $I_R = 1.0A$, $I_{rr} = 0.25A$. See figure 5.

RATINGS AND CHARACTERISTIC CURVES

UF1001 THRU UF1007

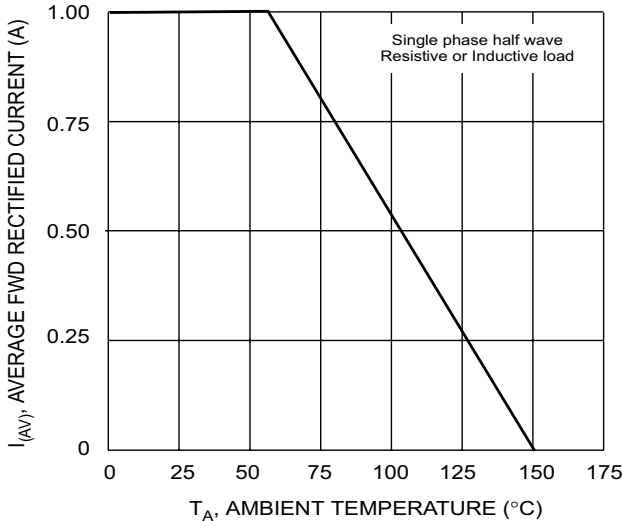

Fig. 1 Forward Current Derating Curve

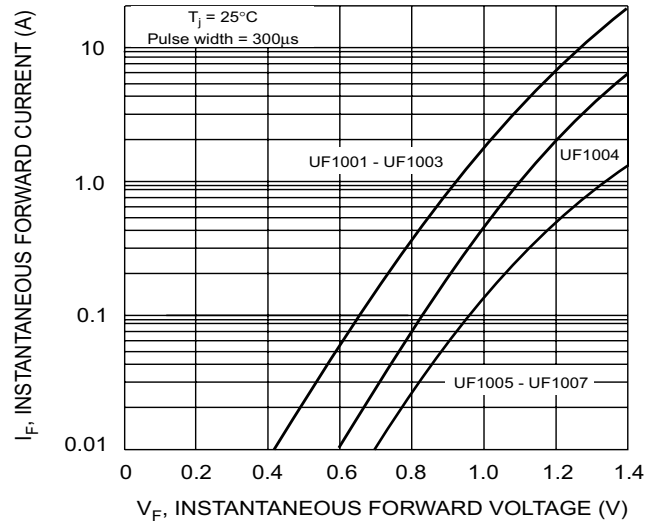

Fig. 2 Typical Forward Characteristics

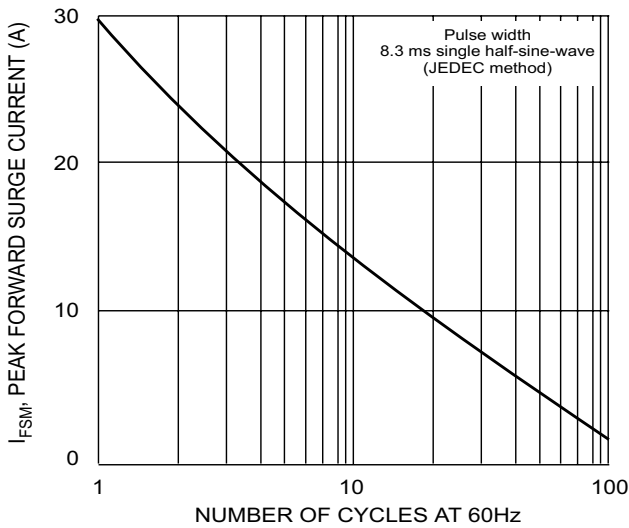

Fig. 3 Peak Forward Surge Current

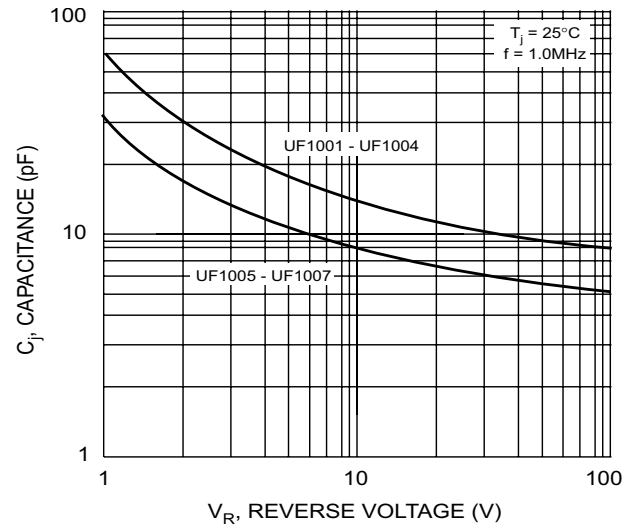
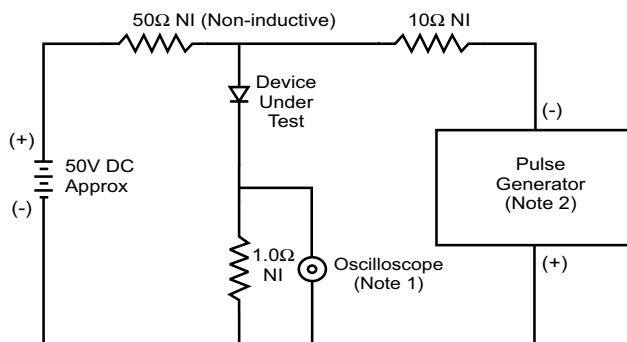
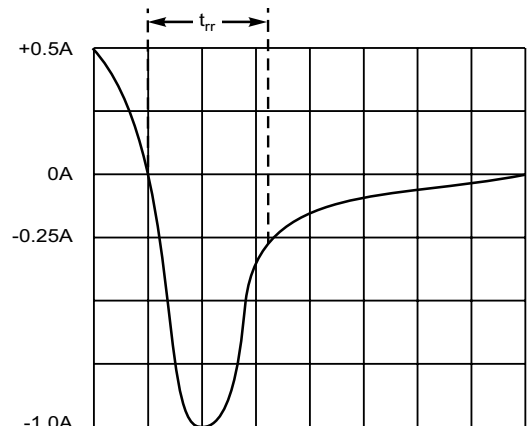

Fig. 4 Typical Junction Capacitance



- Notes:
 1. Rise Time = 7.0ns max. Input Impedance = 1.0M Ω , 22pF.
 2. Rise Time = 10ns max. Input Impedance = 50 Ω .



Set time base for 50/100 ns/cm

Fig. 5 Reverse Recovery Time Characteristic and Test Circuit